

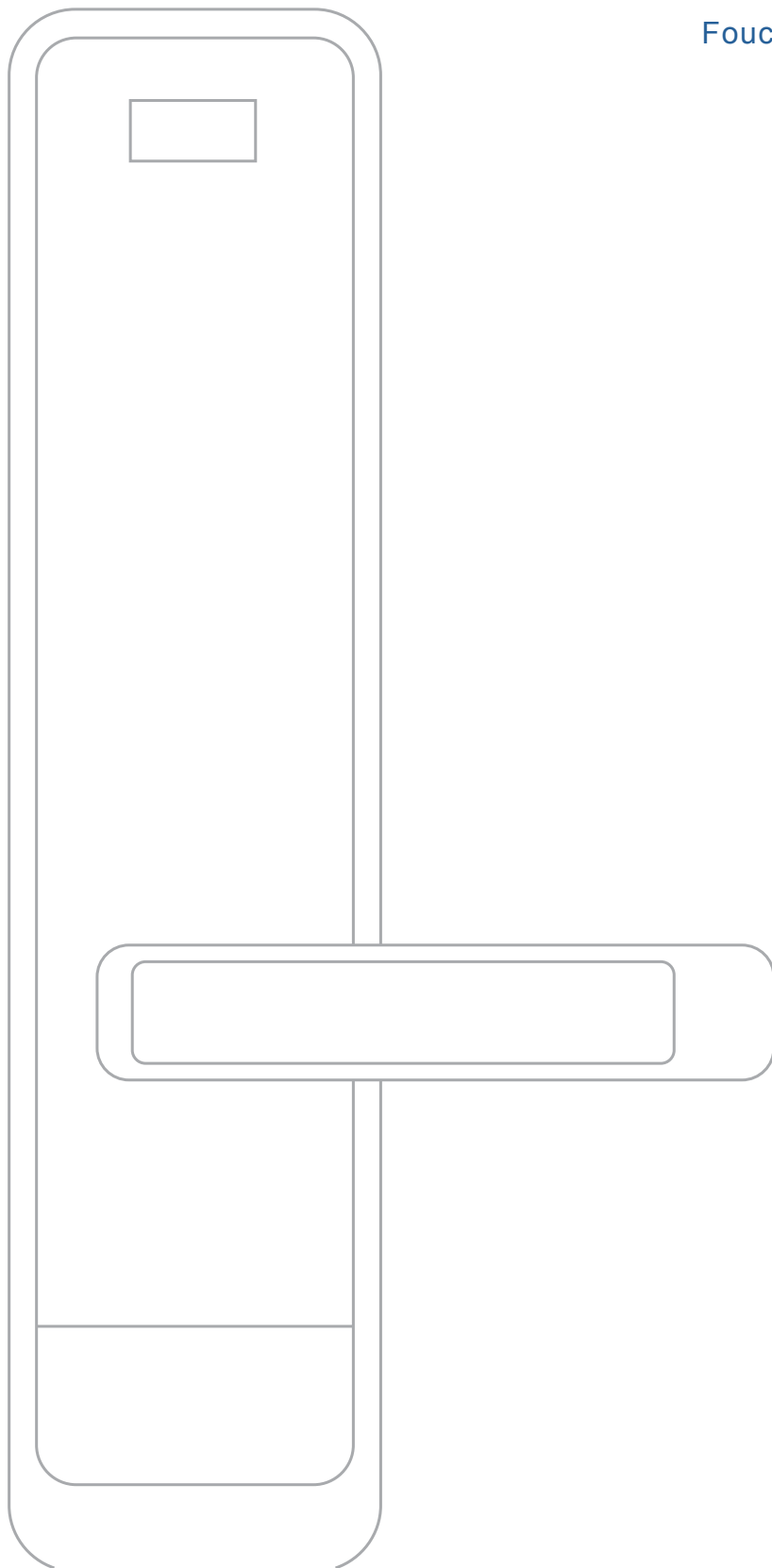

Focused on smart locks solution!





## Company Profile

### Over 13+ Years Of Experience



Ilockey is a leading smart lock company in China, which has specialized in manufacturing and designing smart door locks and electronic cabinet locks for more than 13 years. We provide one-stop smart lock solutions for different places, such as public areas, smart access for private residences, traditional hotels, homestay, and short renting.

Our products include smart door locks, hotel door locks, smart cabinet locks, and lock accessories. All of our smart locks are strictly according to CE, SGS & Europe fire test standards.

### Strong Team of Engineers



In the long-term supply of OEM services to Korean and German customers, we have developed unique insights into our products, and we have integrated our Korean electronic process design and German mechanical motor design into our products to form our unique products style, the electronic locks have been favored and welcomed by the market since the products were launched.

### Efficient Production & Strict QC



Equipped with 2 sets of Die-casting Machine, 2 pcs of Injection machine, 8 pcs of bench drilling machine, 4pcs Puching Machine, 1pc Hydraulic press Machine, 1 pc of SMT Machine and 1 Reflow soldering Machine. At the same time we set up a professional testing department, 3 professional engineers to cooperate with customers for general functional testing, handle torsion spring life test, salt spray test.

### Focused on the Global Market



We are serving foreign customers such as Korea, Germany, USA, Mexico, Japan, Russia, Saudi Arabia, etc., and provide them with professional smart lock manufacturing services .



### Smart lock panel punching machines

All of the stainless steel material smart locks panel must be punched first, there are 4 sets of different tons punching machine to meet different request.



### Fully Automatic SMT

Fully automatic SMT PCB production ensured the stability of our lock CPU, which solved the problem of pseudo soldering, welding leakage and short circuit and guarantee your safety during use.



### Mortise assembly

Mortise is the core part of the smart door lock, it adopts Taiwan's high-quality motor and has a service life of 500,000 times. It has an average of 100 times a day to open the door and has a service life of more than 13 years.



### Smart lock assembly

It is the final process to finish a set of smart door lock, install the handle on the panel, check the function, put mortise into the package together with panel, screw accessories, it is around 18,000 pc/Month final products from the package line.



## Quality Control Procedure



### Switch Life Test

Energy Saving switch is with 24 hours continuous test under wide range 65--260V. Working current capacity is 40 AMP. It is much higher than the normal energy saver in the market.



### High and Low Temperature Test

High and low temperature test for PCB board, which ensure the using life under hot or cold condition. That means no matter your electronic locks used in hot middle east area or in cold Russian market, the lock can be calmly faced.



### Life Span Test

Life span test is the most common test for smart door lock, it related to the quality electronic parts and hardware parts, like fingerprint sensor, handle, spring, mortise, deadbolt and so on.



### Salt-spray Test

The salt spray test is used to test the lock surface rust problem, which ensures that the door lock surface does not rust for 96 hours from -10 to 55 °C. Meets EN standard GradeH. That means it will last for a long time to avoid rusting awkward and troubles for your door lock.



### Reliable High Speed Motor

It adopts Taiwan's high-quality motor and has a service life of 500,000 times. It has an average of 100 times a day to open the door and has a service life of more than 13 years.

## Features & Benefits:



### Classical design

Simple and classic design, you can upgrade the old IC card lock without replacing the mortise.



### Patented mortise structure design

The mortise can interchange the left and right easily. For distributors, they can reduce stock and strengthen the cash flow turnover.



### SUS304 House and Mortise

All of key spare parts are made of SUS 304 material, It is durable and reliable to avoid rusting troubles.



### High-quality Motor

It adopts Taiwan's high-quality motor and has a service life of 500,000 times. Assuming 100 times a day to open the door and it has a life of more than 13 years.

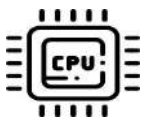

### Main board uniform quality

Fully automatic SMT and full computer detection technology, which effectively guarantees the high quality of the products.



### Audit trail

990 latest records include the mechanical key for query when needed.



### Low battery warning signal

When power is less than 4.8V, there is "dididi" beep then you can still open 150 times.



Mode No: IE300

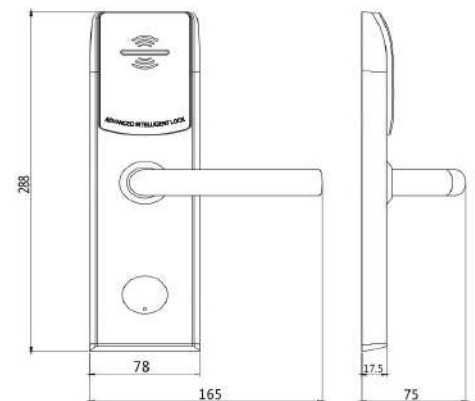

Measurement

<b>Spec info</b>	Power supply	4 AA batteries	Battery life	15000 times
	Static current	≤25μA	Unlock way	Mifare card and mechanical key
	Dynamic current	≤150mA	Net weight	2.7 kg
	Working temperature	-15 ~ +55℃	Door thickness	30--65mm
	Working humidity	20 ~ 95%RH	Reliability	>30,000 times
	Alarm voltage	4.8±0.2V	Application	Hotel, Hospital, School, office....

## Features & Benefits:



### Web software & App

Support Web software and Mobile App management



### Various access

Mobile App, Pincode, Mifare card and key for your option.



### Share Ekey or Code remotely

Send an Ekey, password to guests remotely, Keep social distance.



### Pre-issued password

pre-set activation time password, send customer in advance



### Real Time tracking

The APP can display the door lock opening record, You can know who accessed your lock and when it was accessed. (gateway is necessary)



### Emergency USB power supplier

In case the battery has no power, you can unlock it with power bank.



### SUS304 House and Mortise

All of key spare parts are made of SUS 304 material, It is durable and reliable to avoid rusting troubles.



## Mode No: IE300P-TThotel

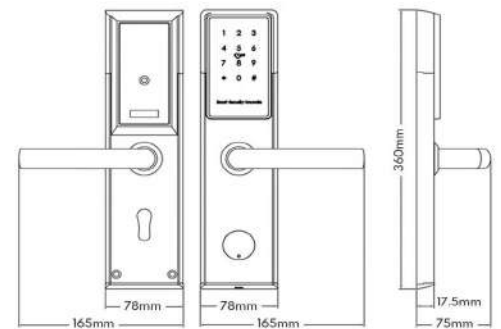

## Measurement

<b>Spec info</b>	Power supply	4 AA batteries	Supported system	Windows web and ISO7.0/Andrio4.4 App
	Static current	≤40μA	Communication	Bluetooth 4.0
	Dynamic current	≤150mA	Battery life	10,000 times
	Working temperature	-15 ~ +55°C	Net weight	2.7kg
	Working humidity	20 ~ 95%RH	Door thickness	30--65mm
	Alarm voltage	4.8±0.2V	Application	Rent property, Middle to big scale hotel



# TTlock Bluetooth Door Lock A210

## Features & Benefits:



### Various access

Mobile App, Fingerprint, Pincode, Mifare card and key for your option.



### Share Ekey or Code remotely

Send an electronic key, password to friends remotely, No more waiting until you back. (gateway needed)



### Pre-issued password

Daily rental suite master favorite, pre-set activation time password, send customer in advance



### Cyclic password

Management center favorite, fixed date and fixed time, password can be reused.



### Real Time tracking

The APP can display the door lock opening record, You can know who accessed your lock and when it was accessed.



### Waterproof design

All sus304 material with super slim waterproof design

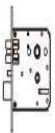

### Multiple mortise size for option

304 stainless steel mortise for option 3585/4585/6085 Euro mortise



## Mode No: A210-TTlock

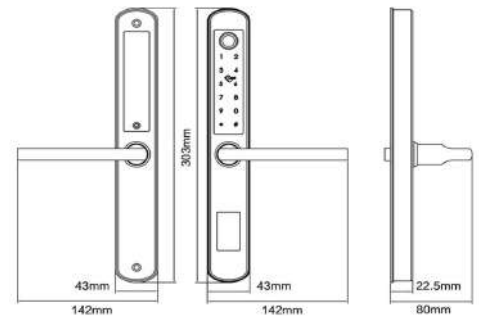

## Measurement

<b>Spec info</b>	Power supply	4 AA batteries	Supported system	iso 7.0 and later or Android 4.4 and later
	Static current	≤25μA	Communication	Bluetooth 4.0
	Dynamic current	≤150mA	Battery life	6000 times
	Working temperature	-15 ~ +55℃	Net weight	2.75kg
	Working humidity	20 ~ 95%RH	Door thickness	35--60mm
	Alarm voltage	4.8±0.2V	Application	Rent apartment, Airbnb, homestay...

## Features & Benefits:



### Various access

Tuya App, Pincode, Mifare card and key for your option.



### Scene Linkage

Supports scene linkage triggered by the door opening.



### Random dynamic code

Send random password to friends remotely, No more waiting until you back.



### Predict password

Management center favorite, fixed date and fixed time, password can be reused.



### Real Time tracking

The APP can display the door lock opening record, You can know who accessed your lock and when it was accessed.



### Waterproof design

Solid Aluminum alloy material with elegant design waterproof design

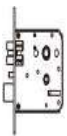

### Multiple latch/mortise size for option

304 stainless steel latch/5050 mortise  
Euro 5572/4585 mortise are available



Mode No: A260-Tuya

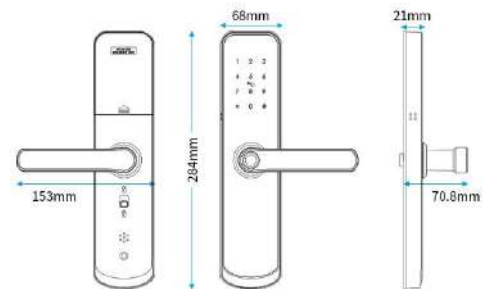

Measurement

<b>Spec info</b>	Power supply	4 AA batteries	Supported system	iso 7.0 and later or Android 4.4 and later
	Static current	≤50μA	Communication	WiFi
	Dynamic current	≤250mA	Battery life	6,000 times
	Working temperature	-15 ~ +55°C	Net weight	2.3kg
	Working humidity	20 ~ 95%RH	Door thickness	30--65mm
	Alarm voltage	4.8±0.2V	Application	Rent apartment, Airbnb, homestay...



## Features & Benefits:



### Various access

Mobile App, Pincode, Mifare card and key for your option.



### Share Ekey or Code remotely

Send an electronic key, password to friends remotely, No more waiting until you back.



### Pre-issued password

Daily rental suite master favorite, pre-set activation time password, send customer in advance



### Cyclic password

Management center favorite, fixed date and fixed time, password can be reused.



### Real Time tracking

The APP can display the door lock opening record, You can know who accessed your lock and when it was accessed.



### Updating Knob

You can update your knob lock with screw driver only.



### Adjustable Latch

50/60/70mm adjustable latch for option



## Mode No: IF008

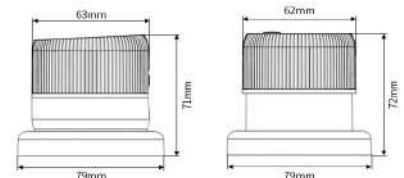

Single Latch  
#50/ #60/ #70 are available



## Measurement

<b>Spec info</b>	Power supply	4 AA batteries	Supported system	iso 7.0 and later or Android 4.4 and later
	Static current	≤25μA	Communication	Bluetooth 4.0
	Dynamic current	≤150mA	Battery life	6000 times
	Working temperature	-15 ~ +55℃	Net weight	1.5kg
	Working humidity	20 ~ 95%RH	Door thickness	30--60mm
	Alarm voltage	4.8±0.2V	Application	Rent apartment, Airbnb, homestay...

## Features & Benefits:



### Various access

Tuya App, Pincode, Mifare card and key for your option.



### Scene Linkage

Supports scene linkage triggered by the door opening.



### Random dynamic code

Send random password to friends remotely, No more waiting until you back.



### Predict password

Management center favorite, fixed date and fixed time, password can be reused.



### Real Time tracking

The APP can display the door lock opening record, You can know who accessed your lock and when it was accessed.



### Waterproof design

Solid Aluminum alloy material with elegant design waterproof design



### Easy installation

Adjustable 60-70 deadbolt  
10 mins enter into smart worlds



Mode No: A220-Tuya

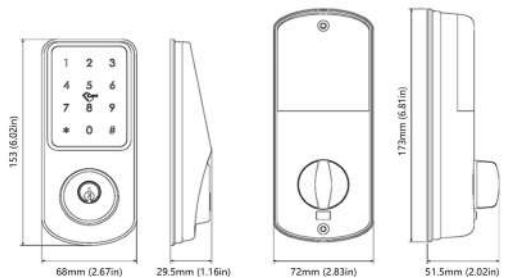

Measurement

<b>Spec info</b>	Power supply	4 AA batteries	Supported system	iso 7.0 and later or Android 4.4 and later
	Static current	≤50μA	Communication	WiFi
	Dynamic current	≤250mA	Battery life	6,000 times
	Working temperature	-15 ~ +55°C	Net weight	1.8kg
	Working humidity	20 ~ 95%RH	Door thickness	35--65mm
	Alarm voltage	4.8±0.2V	Finish	Gray, Black,Satin Nickle

## Features & Benefits:

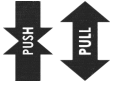

### Humanized push-pull design

After fingerprint recognition, you can open the door lightly. One step is enough!



### User friendly access

Ilockey F8 has four access solutions, fingerprint, Pincode, Mifare card and mechanical key for your option.



### Blind fingerprint recognition

The fingerprint sensor is hidden behind the front handle, effectively increasing safety and service life

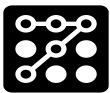

### Anti-peeping password design

you can enter the anti-peeping code before and after the correct password. to avoid awkward in front of your friends.



### Automatic mortise lock

Closed automatically locked, indeed closed and going. If the bolt is not entirely stretched, the lock will be alarmed.



### Fast escape function

One button for emergency escape for emergency situation.



### Emergency USB power supplier

In case the battery has no power, you can unlock it with power bank.



Mode No: F8

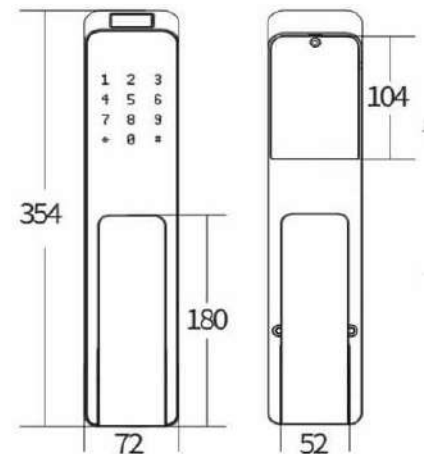

Measurement

<b>Spec info</b>	Power supply	4 AA batteries	Fingerprint	100 group
	Static current	≤25μA	Digital	10 group
	Dynamic current	≤200mA	Card	100 group
	Working temperature	"-10 ~ +60℃	Battery life	8000 times
	Working humidity	20 ~ 95%RH	Net weight	5kg
	Alarm voltage	4.8±0.2V	Door thickness	40--110mm

## Features & Benefits:



### Unique Design

Unique design with appearance patent.  
Small handle for easy grip



### Simple & Security management

Simple program & Operation just by a handset.  
Without software, non-professionals can operate it easily.



### Master card for emergency

Master card is used to control the whole project  
and for emergency unlocking.



### Freedom of card & storage

Any mifare card can be a user card after programmed.  
Any one card can be use anyone locker at any time.



### Alarm

Alarm will on and last 30 seconds if anyone  
attempts to open the lock by illegal card.



### Low battery warning signal

A continuous "beep" sound during door access  
will alert you to replace batteries.



### Emergency USB power supplier

In case the battery has no power,  
you can unlock it with power bank.



**Mode No: IC878B**

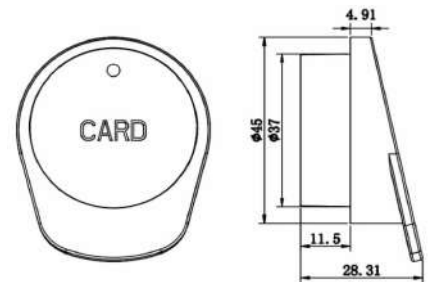

**Measurement**

<b>Spec info</b>	Power supply	3 x AA batteries	Access card	Master Card: 3 pcs
	Battery life	12 ~ 15 months		User Card: any programmed card
	Static current	≤20μA	Multiple cards	Wrist band, card, tag
	Dynamic current	≤200mA	Net weight	0.15kg
	Working temperature	-15 ~ +55℃	Door thickness	≥ 11mm
	Working humidity	20 ~ 95%RH	Application	Hot spring centres, Spas, Theme parks
	Alarm voltage	3.7±0.2V		Gym, office, school locker, Banks ...

## Features & Benefits:



### Classical Design

Classical design for hot selling many years.  
SUS304 material and durable rust.



### Lever management

Secure control by Lever management  
Clear rights and responsibilities, easy to manage



### Manual or auto-locking optional

You can chose manual locking or auto-locking according to management



### Operation status notification

Occupied lock will blinks to show the locker in use.



### Alarm

Alarm will on and last 30 seconds if anyone attempts to open the lock by illegal card.



### Low battery warning signal

A continuous "beep" sound during door access will alert you to replace batteries.



### Emergency power backup

In case the battery has no power, you can unlock it with emergency backup.



Mode No: IC806

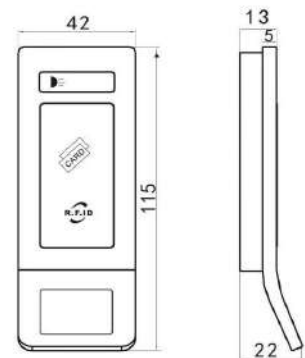

Measurement

<b>Spec info</b>	Power supply	3 x AA batteries	User Access Code	Master Card: 3 pcs
	Battery life	12~15 months		Guest Card:5 pcs
	Static current	≤20μA		One time code:1 pc
	Dynamic current	≤200mA	Multiple cards	Wrist band, card,tag
	Working temperature	-15 ~ +55℃	Net weight	0.18kg
	Working humidity	20 ~ 95%RH	Door thickness	≥ 1mm
	Alarm voltage	3.7±0.2V	Application	Gym,office,school locker...

## Features & Benefits:



### Multiple access

Ilokey IF920 has two access solutions, Fingerprint, pincode for your convenience.



### Backlight Keypad

Keypad with backlight for easy distinction at dark.



### Operation status notification

When any operation is made, the LED indicator informs you what is happened through different color and blinking.



Mode No: IF920



### Automatic locking

Cabinet lock will be locked automatically after opening door a few seconds.



### Master key

When someone left the company, you can unlock via master key.



### Low battery warning signal

A continuous "beep" sound during door access will alert you to replace batteries.

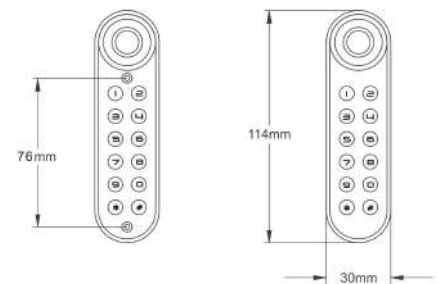

Measurement



### Emergency USB power supplier

In case the battery has no power, you can unlock it with power bank.

Spec info	Power supply	3 x AA batteries	Life Span	200,000 times
	Battery life	>4500 times	Users	50 pcs
	Static current	≤20μA	Programmable	1--10 digit combination
	Dynamic current	≤220mA	Net weight	0.20kg
	Working temperature	-15 ~ +55℃	Door thickness	≥ 3mm
	Working humidity	20 ~ 95%RH	Application	customized furniture, drawer, office,
	Alarm voltage	3.6±0.2V		Banks, school file cabinet...

## Features & Benefits:



### Multiple access

Unique design with biometric access



### Unique design

Seamless connection with draw



### Operation status notification

LED indicator informs you what is happened through different color and blinking.



### Automatic locking

Cabinet lock will be locked automatically after opening door a few seconds.



### Master key

When someone left the company, you can unlock via USB master key.



### Low battery warning signal

A continuous "beep" sound during door access will alert you to replace batteries.



### Emergency USB power supplier

In case the battery has no power, you can unlock it with power bank.



Mode No: IF930

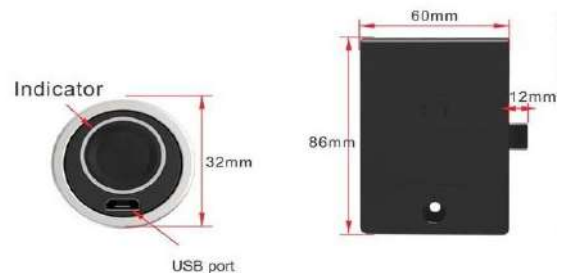

Measurement

Spec info	Power supply	3 x AA batteries	Life Span	200,000 times
	Battery life	>4500 times	Users	20 pcs
	Static current	≤20μA	Programmable	1--10 digit combination
	Dynamic current	≤220mA	Net weight	0.20kg
	Working temperature	-15 ~ +55℃	Door thickness	≥ 15mm
	Working humidity	20 ~ 95%RH	Application	customized furniture, drawer, office,
	Alarm voltage	3.6±0.2V		Banks, school file cabinet...

## Features & Benefits:



### Lever management

Secure control by Lever management  
Clear rights and responsibilities, easy to manage



### Various access

Ilokey IC906 has two access solutions,  
Pincode or Temic card for your convenience.



### Backlight Keypad

Keypad with backlight for easy distiction at dark.



## Mode No: IC915



### Automatic locking

Cabinet lock will be locked automatically  
after opening door a few seconds.



### Alarm(Incorrect PIN code attempt)

Alarm will on and last30 seconds if anyone  
attempts to open the lock by incorrect Pin or  
ilegal card



### Low battery warning signal

A continuous"beep" sound during door access  
will alert you to replace batteries.



### Emergency power backup

In case the battery has no power,  
you can unlock it with emergency power.

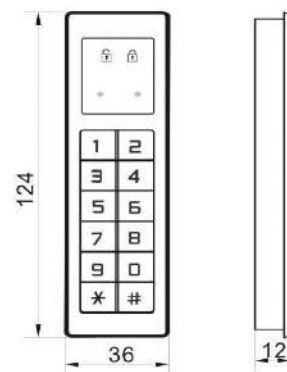

## Measurement

Spec info	Power supply	3 x AA batteries	User Access Code	Master Card: 3 pcs
	Battery life	12~15 months		Guest Card/code:5 pcs
	Static current	≤20μA		One time code:1 pc
	Dynamic current	≤200mA	Multiple cards	Wrist band, card,tag
	Working temperature	-15 ~ +55 °C	Net weight	0.18kg
	Working humidity	20 ~ 95%RH	Door thickness	≥ 1mm
	Alarm voltage	3.7±0.2V	Application	Gym,office,school locker...





## Exhibitions&Customers



HOTELPLUS Shanghai 2019



121th Canton Fair 2017



2018 Hamburg Messe und



2016 SEOUL FOOD & HOTEL



2014 Dubai Big 5





### **Isabel from Germany(Technical Engineer)**

Thanks so much for all your hard work and efficiency on our project, you know your fingerprint lock F1 design is so elegant and super quality. (past 300,000 times test already) At the meantime, I like the way you were asking me for details, providing me feedback before making deals. That's showing me you care for my feeling rather than hurry to close the deal. we have applied the further test from BV test lab for formal certificate till now everything goes well, hope we have extensive cooperation in near future.



### **Dimi from the UK**

You have dealt with my order so successfully, so professionally on fingerprint lock and with a lot of hardware and security knowledge. I can also say that I deemed a lot of comfort and confidence during a very upsetting period. I can see comfortably 100% recommend ilockey technology to anyone. Thank you!



### **Gaurav from Australia(After sales Manager)**

I am pleased with the prompt response from your side whenever I needed your support regarding any confusion in installation or software. Secondly, I am pleased with the quality of the products supplied by you. Your professional approach towards the building of a long-term business relationship is always reflected in the products provided by you and the prompt services after sales, which has always helped us to get referral business from our happy clients.  
It is always a pleasure to work with you



### **Ricardo from Mexico(General Manager)**

Thanks so much for all your great efforts on our fingerprint lock project, Sun and I have been impressed and want to extend our heartfelt appreciation. We were also grateful for the hard working your engineer Guo made on the simple but fashion desian: it Impressed us.



AMERIAN CARLOS



Arona Hotel



Ashirwad Hotel



Best western



BW GROUP



Cromhotels



Crystal Hotel Russia



Dechen Palmos



Ephesus princess hotel



Gosin University hotel



Gyongbok University



HOTEL BICENTENARIO



Hotel Gualok



Hotel MM Paradise



HOTEL QUORUM



HOTEL TURISMO DE FORMOSA



Hward Jonson



HwardJonson



Kabul palace



LOS NARANJOS



Mallak APART HOTEL



Mansion Hotel



QUIRINALE



RAMADA



Royal shelton Hotel



Shelton Hotel



Swan Lake



The Regent Hotels



Yacht Golf Hotel



De La Vita

## **Shenzhen Ilockey Technology Co.,Ltd**

Tel:+86-755-84046958 Fax:+86-755-84046959  
Email:info@ilockey.com Web:www.ilockey.com  
Add:20F Shuipan building, No 3193  
Binghe Avenue, Futian District, Shenzhen

